

**DO NOT SCALE DRAWING
THIRD ANGLE PROJECTION**

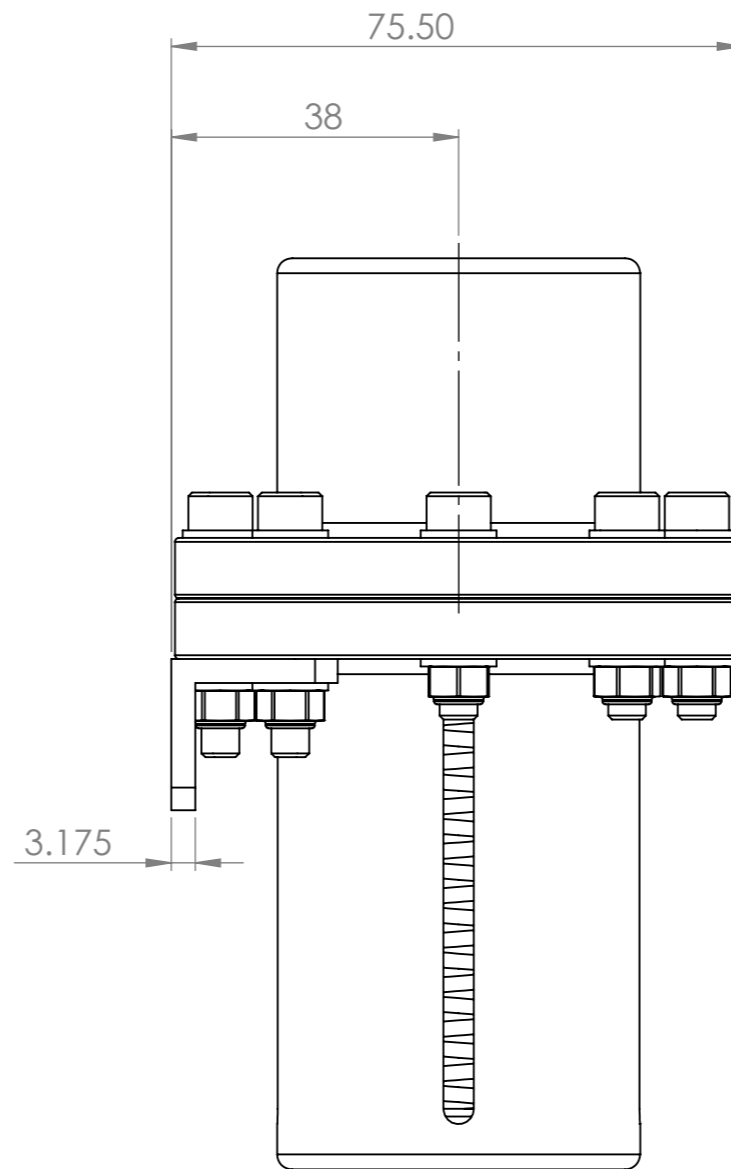
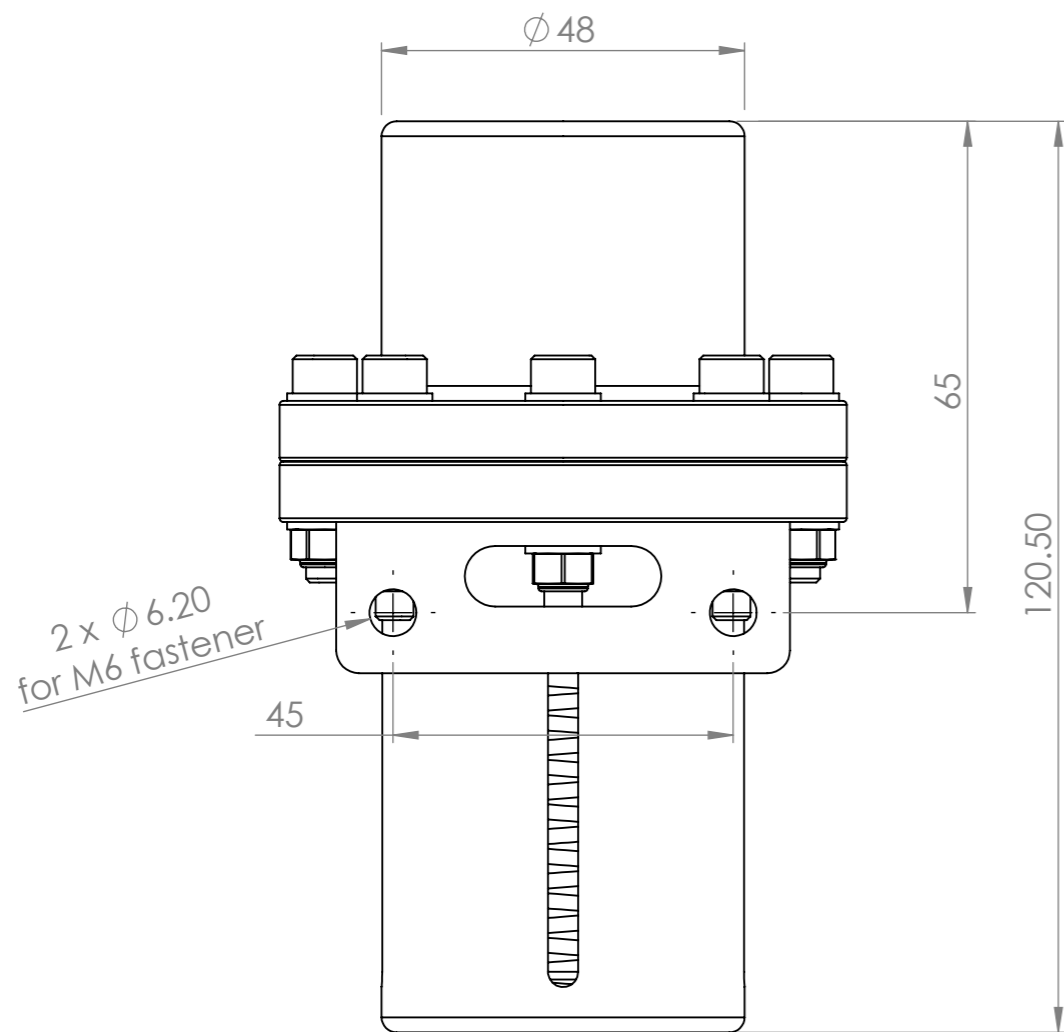
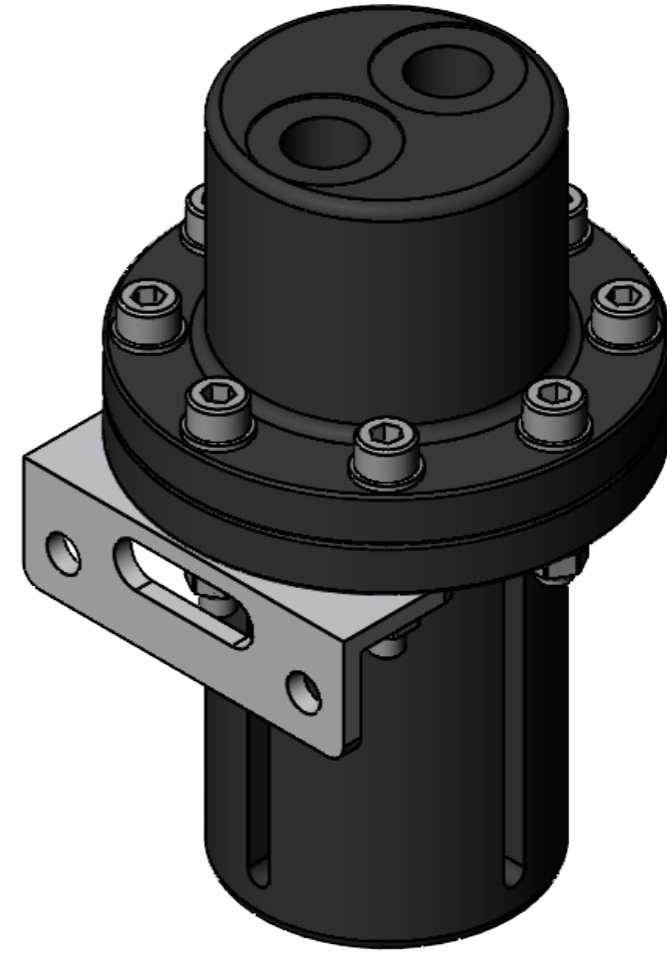
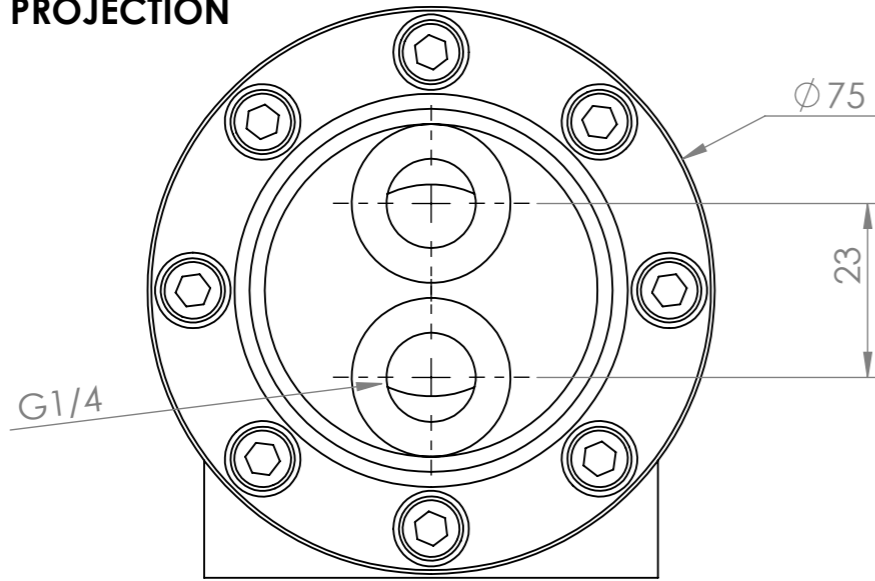

NOTES

1. Compensator capacity: 74cc
2. Max working pressure: 1.1bar

| REV | DRAWN | APPV'D | DATE | DESCRIPTION |
|-----|-------|--------|----------|------------------------|
| 1 | DGM | | 18/07/24 | ISSUED FOR INFORMATION |

RECORD OF REVISIONS

Macduff Robotics Ltd
Aberdeen, Scotland.
www.macduff-robotics.com
enquiries@macduff-robotics.com

MATERIAL:
-
FINISH:
-
TOLERANCE:
+/- 0.1mm
WEIGHT:

TITLE:
**74cc Compensator
Assembly - 2x 1/4G**
SHEET 1 OF 1

DWG NO. **GA0068**
SCALE:1:1
REVISION **1**
A3

DIMENSIONS ARE IN MILLIMETERS, UNLESS OTHERWISE SPECIFIED